

UBUHLEBEZWE MUNICIPALITY



TENDER REGISTER

Tender Number : UBU-B-03/09/2019
Tender Closing : 12:00
Closing Date : 06 MARCH 2020

Description : MUNICIPAL CORPORATE BRANDING 24 MONTHS (RE-ADVERTISEMENT)

Officials Present:
NAME

SIGNATURE

NAME	SIGNATURE
ARTHINE MGIJANE	
Jo-Anne Nyamiso	
Thabile Mpanza	

NUMBER OF TENDERS RECEIVED

05 

Item	Name of Supplier	Price Tendered	Signature	BBBEE LEVEL
1	KUHLE AND LWANDLE PROJECTS	R1 - R5323407 R2 - R6148,95		1
2	AMILE HOLDINGS (PTY)	R111 321,00		1
3	EMBENGENI PROJECTS (PTY)	R115 125,00		1
4	FIRIQA TECH	R105 892,59		1
5	POORNA ENTERPRISES	R199 739,10		1
6				
7				
8				
9				
10				
11				
12				
13				
14				
15				
16				

17					
18					
19					
20					
21					
22					
23					
24					
25					

COMMENTS: _____

UBUHLEBEZWE MUNICIPALITY

PUBLIC NOTICE

AMENDMENT OF 2019/2020 INTEGRATED DEVELOPMENT PLAN

Notice is hereby given that, in terms of Municipal planning and performance management legislation which states that no amendment to a Municipality's Integrated Development Plan may be adopted by the Municipal Council unless the proposed amendment has been published for public comment for a period of at least 21 days in a manner that allows the public an opportunity to make representations with regard to the proposed amendment.

The Ubuhlebezwe Municipality invites the local community to provide comments and make representations in light of the proposed amendments. The Council meeting will be held on 20 February 2020, 16h00 at Soweto Hall.

Copies of the proposed amendments are available at the Main Municipal offices reception and Municipal Library.

For further enquiries, contact: The IDP/PMS Manager, Mr. C. Mthembu, on tel: 027 01 34 271 5100, during office hours.

S.M. SHIKE: MUNICIPAL MANAGER

NOUTHU MUNICIPALITY

JMASIPALA WASE NOUTHU

Private Bag X5521, Nouthu, 3105

Tel: +27(0) 34 271 5100, Fax: +27(0) 371 5111

PUBLIC NOTICE

DRAFT ANNUAL REPORT 2019/2020

Notice is hereby given that, in terms of Section 127(1)(a) of the Municipal Finance Management Act No. 56 of 2003 that the annual report for 2019/2020 has been prepared and placed in the Council Meeting room as per on 27 January 2020.

The draft report is available for public viewing at the reception point of municipal offices, municipal libraries and municipal website: www.nouthu.gov.za

For further enquiries, contact the IDP/PMS Manager, Mr. M. Ngobee at 03- 271 5111 or info@nouthu.gov.za

2019/2020 MID-YEAR BUDGET AND PERFORMANCE ASSESSMENT

Notice is hereby given that, in terms of Section 70(1) of the Municipal Finance Management Act No. 56 of 2003 that the accounting officer of a municipality must by 28 January of each year assess the performance of the municipality during the first half of the financial year. The 2019/2020 mid-year budget and performance assessment report has been prepared and tabled in the Council meeting that was held on Friday 01 January 2020.

Documents are available for public viewing at the reception point of municipal offices, municipal libraries and municipal website: www.nouthu.gov.za

For further enquiries, contact the IDP/PMS Manager, Mr. M. Ngobee at 03- 271 5111 or info@nouthu.gov.za

BP GUME: MUNICIPAL MANAGER

BP GUME

UBUHLEBEZWE MUNICIPALITY

Department of Agriculture and Rural Development

The Integrated Rural Development of Agriculture and Rural Development, covers eight (8) projects for the following:

Reference Number	Publication	Description	Cost for Document	Compulsory Site Briefing Dates and Time
DBP-2019-01	Open tenders via most e-tendering systems responsible for the provision of section 41(1)(b) of the PFMA Regulations, 2017	Supply, Deliver and install fencing material of 117 km for Riepport Farm in Greater KwaZulu Agricultural Office	R170 000	Venue: Department of Agriculture and Rural Development, District Research Station Date: 11/02/2020 Time: 11h00
DBP-2019-02	Pre-qualification criteria may respond to the provision of section 41(1)(b) of the PFMA Regulations, 2017	Supply, Deliver and install fencing material of 117 km for Riepport Farm in Greater KwaZulu Agricultural Office	R170 000	Venue: Department of Agriculture and Rural Development, District Research Station Date: 11/02/2020 Time: 11h00
DBP-2019-03	Pre-qualification criteria may respond to the provision of section 41(1)(b) of the PFMA Regulations, 2017	Supply, Deliver and install fencing material of 117 km for Riepport Farm in Greater KwaZulu Agricultural Office	R170 000	Venue: Department of Agriculture and Rural Development, District Research Station Date: 11/02/2020 Time: 11h00
DBP-2019-04	Pre-qualification criteria may respond to the provision of section 41(1)(b) of the PFMA Regulations, 2017	Supply, Deliver and install fencing material of 117 km for Riepport Farm in Greater KwaZulu Agricultural Office	R170 000	Venue: Department of Agriculture and Rural Development, District Research Station Date: 11/02/2020 Time: 11h00
DBP-2019-05	Pre-qualification criteria may respond to the provision of section 41(1)(b) of the PFMA Regulations, 2017	Supply, Deliver and install fencing material of 117 km for Riepport Farm in Greater KwaZulu Agricultural Office	R170 000	Venue: Department of Agriculture and Rural Development, District Research Station Date: 11/02/2020 Time: 11h00
DBP-2019-06	Pre-qualification criteria may respond to the provision of section 41(1)(b) of the PFMA Regulations, 2017	Supply, Deliver and install fencing material of 117 km for Riepport Farm in Greater KwaZulu Agricultural Office	R170 000	Venue: Department of Agriculture and Rural Development, District Research Station Date: 11/02/2020 Time: 11h00
DBP-2019-07	Pre-qualification criteria may respond to the provision of section 41(1)(b) of the PFMA Regulations, 2017	Supply, Deliver and install fencing material of 117 km for Riepport Farm in Greater KwaZulu Agricultural Office	R170 000	Venue: Department of Agriculture and Rural Development, District Research Station Date: 11/02/2020 Time: 11h00
DBP-2019-08	Pre-qualification criteria may respond to the provision of section 41(1)(b) of the PFMA Regulations, 2017	Supply, Deliver and install fencing material of 117 km for Riepport Farm in Greater KwaZulu Agricultural Office	R170 000	Venue: Department of Agriculture and Rural Development, District Research Station Date: 11/02/2020 Time: 11h00

For further enquiries, contact: The IDP/PMS Manager, Mr. C. Mthembu, on tel: 027 01 34 271 5100, during office hours.

S.M. SHIKE: MUNICIPAL MANAGER

UBUHLEBEZWE MUNICIPALITY

INVITATION TO BID

Ubuhlebezwe Municipality invites suitable, qualified and experienced service provider to provide services to the Municipality.

PROJECT NAME	BID NO	BID GRADING	COMPULSORY BIDDING SESSION	AVAILABILITY OF TENDER DOCUMENTS	BID OPENING DATE AND TIME	CLOSING DATE
Drainage System for 10 connections Project	UBM-2019-01	C or Higher	16 February 2020 at 10h00	12 February 2020 at the Council's Office (Business Hours 08h00 to 16h00)	17 February 2020 at the Council's Office (Business Hours 08h00 to 16h00)	17 February 2020 at 10h00
Local maintenance transformer and cables	UBM-2019-02	C or Higher	16 February 2020 at 10h00	12 February 2020 at the Council's Office (Business Hours 08h00 to 16h00)	17 February 2020 at the Council's Office (Business Hours 08h00 to 16h00)	17 February 2020 at 10h00
Local maintenance transformer and cables	UBM-2019-03	C or Higher	16 February 2020 at 10h00	12 February 2020 at the Council's Office (Business Hours 08h00 to 16h00)	17 February 2020 at the Council's Office (Business Hours 08h00 to 16h00)	17 February 2020 at 10h00
Local maintenance transformer and cables	UBM-2019-04	C or Higher	16 February 2020 at 10h00	12 February 2020 at the Council's Office (Business Hours 08h00 to 16h00)	17 February 2020 at the Council's Office (Business Hours 08h00 to 16h00)	17 February 2020 at 10h00
Local maintenance transformer and cables	UBM-2019-05	C or Higher	16 February 2020 at 10h00	12 February 2020 at the Council's Office (Business Hours 08h00 to 16h00)	17 February 2020 at the Council's Office (Business Hours 08h00 to 16h00)	17 February 2020 at 10h00
Local maintenance transformer and cables	UBM-2019-06	C or Higher	16 February 2020 at 10h00	12 February 2020 at the Council's Office (Business Hours 08h00 to 16h00)	17 February 2020 at the Council's Office (Business Hours 08h00 to 16h00)	17 February 2020 at 10h00
Local maintenance transformer and cables	UBM-2019-07	C or Higher	16 February 2020 at 10h00	12 February 2020 at the Council's Office (Business Hours 08h00 to 16h00)	17 February 2020 at the Council's Office (Business Hours 08h00 to 16h00)	17 February 2020 at 10h00
Local maintenance transformer and cables	UBM-2019-08	C or Higher	16 February 2020 at 10h00	12 February 2020 at the Council's Office (Business Hours 08h00 to 16h00)	17 February 2020 at the Council's Office (Business Hours 08h00 to 16h00)	17 February 2020 at 10h00

For further enquiries, contact: The IDP/PMS Manager, Mr. C. Mthembu, on tel: 027 01 34 271 5100, during office hours.

S.M. SHIKE: MUNICIPAL MANAGER

Ubuhlebezwe Municipality invites suitable, qualified and experienced service provider to provide services to the Municipality.

For further enquiries, contact: The IDP/PMS Manager, Mr. C. Mthembu, on tel: 027 01 34 271 5100, during office hours.

S.M. SHIKE: MUNICIPAL MANAGER

NOTICES



INVITATION TO BID

DUT 373: Appointment of a Contractor to Undertake Water Harvesting with Irrigation and Refurbishment Project at the Durban University of Technology: Ritson and Steve Biko Campuses (Only 4 CE or Higher CIBS Grading)

The University wishes to appoint service providers for the above Bid. The contract & service provider must have relevant experience and capability.

The Durban University of Technology (DUT) fully endorses and supports the Black Economic Empowerment Programme and applies the provisions of the Preferential Procurement Policy Framework (PPF).

Preference will be given to qualifying tenders who may not have had opportunities for projects at DUT in the past.

The tender documents will be available for collection from the Procurement Department located at Block A, Ground Floor (opposite Main Security) M.L. Sultan Campus, 41-43 M.L. Sultan Road, Durban from 02 February 2020 at 14h00.

A non-refundable fee of R1600 per Bid document is applicable (cash, bank-guaranteed cheque or swipe card payments) is payable before collection of the Bid document, or alternatively an EFT payment can be made into the University's bank account as set out below before collection of tender documents.

Account Name: Durban University of Technology, Bank: Standard Bank, Durban Main Branch Code: 046626, Account No.: 95 699 7655.

Reference: DUT 373. Proceed with an EFT when collecting the tender.

Please note cash payments may only be made on the M.L. Sultan Campus, Durban.

The compulsory briefing session will be held as follows:

Bid Number	Date and Time	Venue
DUT 373	16 February 2020 at 10h00	DUT Ritson Campus Durban, Manufacture Entrance, Ritson Campus 1, Ritson Road, Overport Durban, 4001

No tender documents will be issued during or after the compulsory briefing session.

Tenders will be opened publicly. Prospective tenders are required to attend the opening.

Documentation submitted is subject to verification. Should the information submitted be found to be invalid, your tender will be immediately disqualified.

Tenders addressed to the Durban University of Technology, must be submitted in a sealed envelope and deposited in the tender box, located at the Procurement Department, 41-43 M.L. Sultan Road, M.L. Sultan Campus, Durban by no later than Wednesday, 19 February 2020 at 11h00.

Tender Documentation Enquiries: email: Innocentlad@dut.ac.za
No late/faxed or e-mailed tenders will be accepted under any circumstance.
"DUT RESERVES THE RIGHT TO AWARD OR NOT TO AWARD THIS TENDER"

www.upstream.co.za

UBUHLEBEZWE MUNICIPALITY INVITATION TO BID

Ubuhlebezwe Municipality invites qualified and experienced service providers to provide services to the Municipality.

PROJECT NAME	DUT NO.	CEO ENQUIRY	COMPLIANT BIDDING SESSION	AVAILABILITY OF TENDER DOCUMENTS	NON-REFUNDABLE PRICE	CLOSING DATE
Initial Development of the 41-43 M.L. Sultan Campus, Durban, Durban University of Technology (DUT) 373: Appointment of a Contractor to Undertake Water Harvesting with Irrigation and Refurbishment Project at the Durban University of Technology: Ritson and Steve Biko Campuses (Only 4 CE or Higher CIBS Grading)	UBUHLEBEZWE 2020/01	16 February 2020 at 10h00	16 February 2020 at 10h00	11 February 2020 at 14h00 to 17 February 2020 at 14h00 Durban's Office Building, Durban 4001	R1600 per Bid document (cash, bank-guaranteed cheque or swipe card payments)	19 February 2020 at 11h00
Initial Development of the 41-43 M.L. Sultan Campus, Durban, Durban University of Technology (DUT) 373: Appointment of a Contractor to Undertake Water Harvesting with Irrigation and Refurbishment Project at the Durban University of Technology: Ritson and Steve Biko Campuses (Only 4 CE or Higher CIBS Grading)	UBUHLEBEZWE 2020/01	16 February 2020 at 10h00	16 February 2020 at 10h00	11 February 2020 at 14h00 to 17 February 2020 at 14h00 Durban's Office Building, Durban 4001	R1600 per Bid document (cash, bank-guaranteed cheque or swipe card payments)	19 February 2020 at 11h00
Initial Development of the 41-43 M.L. Sultan Campus, Durban, Durban University of Technology (DUT) 373: Appointment of a Contractor to Undertake Water Harvesting with Irrigation and Refurbishment Project at the Durban University of Technology: Ritson and Steve Biko Campuses (Only 4 CE or Higher CIBS Grading)	UBUHLEBEZWE 2020/01	16 February 2020 at 10h00	16 February 2020 at 10h00	11 February 2020 at 14h00 to 17 February 2020 at 14h00 Durban's Office Building, Durban 4001	R1600 per Bid document (cash, bank-guaranteed cheque or swipe card payments)	19 February 2020 at 11h00
Initial Development of the 41-43 M.L. Sultan Campus, Durban, Durban University of Technology (DUT) 373: Appointment of a Contractor to Undertake Water Harvesting with Irrigation and Refurbishment Project at the Durban University of Technology: Ritson and Steve Biko Campuses (Only 4 CE or Higher CIBS Grading)	UBUHLEBEZWE 2020/01	16 February 2020 at 10h00	16 February 2020 at 10h00	11 February 2020 at 14h00 to 17 February 2020 at 14h00 Durban's Office Building, Durban 4001	R1600 per Bid document (cash, bank-guaranteed cheque or swipe card payments)	19 February 2020 at 11h00
Initial Development of the 41-43 M.L. Sultan Campus, Durban, Durban University of Technology (DUT) 373: Appointment of a Contractor to Undertake Water Harvesting with Irrigation and Refurbishment Project at the Durban University of Technology: Ritson and Steve Biko Campuses (Only 4 CE or Higher CIBS Grading)	UBUHLEBEZWE 2020/01	16 February 2020 at 10h00	16 February 2020 at 10h00	11 February 2020 at 14h00 to 17 February 2020 at 14h00 Durban's Office Building, Durban 4001	R1600 per Bid document (cash, bank-guaranteed cheque or swipe card payments)	19 February 2020 at 11h00
Initial Development of the 41-43 M.L. Sultan Campus, Durban, Durban University of Technology (DUT) 373: Appointment of a Contractor to Undertake Water Harvesting with Irrigation and Refurbishment Project at the Durban University of Technology: Ritson and Steve Biko Campuses (Only 4 CE or Higher CIBS Grading)	UBUHLEBEZWE 2020/01	16 February 2020 at 10h00	16 February 2020 at 10h00	11 February 2020 at 14h00 to 17 February 2020 at 14h00 Durban's Office Building, Durban 4001	R1600 per Bid document (cash, bank-guaranteed cheque or swipe card payments)	19 February 2020 at 11h00
Initial Development of the 41-43 M.L. Sultan Campus, Durban, Durban University of Technology (DUT) 373: Appointment of a Contractor to Undertake Water Harvesting with Irrigation and Refurbishment Project at the Durban University of Technology: Ritson and Steve Biko Campuses (Only 4 CE or Higher CIBS Grading)	UBUHLEBEZWE 2020/01	16 February 2020 at 10h00	16 February 2020 at 10h00	11 February 2020 at 14h00 to 17 February 2020 at 14h00 Durban's Office Building, Durban 4001	R1600 per Bid document (cash, bank-guaranteed cheque or swipe card payments)	19 February 2020 at 11h00
Initial Development of the 41-43 M.L. Sultan Campus, Durban, Durban University of Technology (DUT) 373: Appointment of a Contractor to Undertake Water Harvesting with Irrigation and Refurbishment Project at the Durban University of Technology: Ritson and Steve Biko Campuses (Only 4 CE or Higher CIBS Grading)	UBUHLEBEZWE 2020/01	16 February 2020 at 10h00	16 February 2020 at 10h00	11 February 2020 at 14h00 to 17 February 2020 at 14h00 Durban's Office Building, Durban 4001	R1600 per Bid document (cash, bank-guaranteed cheque or swipe card payments)	19 February 2020 at 11h00
Initial Development of the 41-43 M.L. Sultan Campus, Durban, Durban University of Technology (DUT) 373: Appointment of a Contractor to Undertake Water Harvesting with Irrigation and Refurbishment Project at the Durban University of Technology: Ritson and Steve Biko Campuses (Only 4 CE or Higher CIBS Grading)	UBUHLEBEZWE 2020/01	16 February 2020 at 10h00	16 February 2020 at 10h00	11 February 2020 at 14h00 to 17 February 2020 at 14h00 Durban's Office Building, Durban 4001	R1600 per Bid document (cash, bank-guaranteed cheque or swipe card payments)	19 February 2020 at 11h00

The Bidding Process involves the "BID NAME AND THE RELEVANT DUT NO." must be provided on the bid to be opened by the Durban University of Technology (DUT) 373: Appointment of a Contractor to Undertake Water Harvesting with Irrigation and Refurbishment Project at the Durban University of Technology: Ritson and Steve Biko Campuses (Only 4 CE or Higher CIBS Grading). The name of the bidder must be clearly written on the sealed envelope containing the bid.

NB: No bid opened and the bid must be kept 30 minutes before the start of the bidding session for Municipality Corporate branding by the service provider. Configuration of bid from internet service providers, computer services, and other services, must be clearly written on the bid. Documents will NOT be opened. Bid documents and tender documents are available on the website.

Tender documents are available on the website: www.durbanuniversityoftechnology.ac.za and www.ubuhlebezwe.gov.za

Enquiries regarding this notice may be directed as follows: Municipality, 41-43 M.L. Sultan Road, Durban 4001. Tel: 031 261 1111. Fax: 031 261 1112. Email: info@ubuhlebezwe.gov.za or info@durbanuniversityoftechnology.ac.za

NOTE: Late bids or bids received by way of post, facsimile or e-mail will, under no circumstances, be considered.

The Municipality/Ubuhlebezwe Municipality is not responsible for the consequences of any delay in the opening of the bids. The Municipality/Ubuhlebezwe Municipality will not be responsible for the consequences of any delay in the opening of the bids. The Municipality/Ubuhlebezwe Municipality will not be responsible for the consequences of any delay in the opening of the bids.

Djokick as Worrier one

Unbeatable Serbian dominating the Australian Open

Novak Djokovic was the initial favourite to win the Australian Open, but he was not the only one to be a contender. The Serbian dominated the tournament, defeating his opponent in the final to claim his 11th Grand Slam title. Djokovic's performance was exceptional, as he won all five sets in the final, a feat that has not been achieved since Andre Agassi's victory over Andre Agassi in 2001. Djokovic's dominance was evident from the start, as he won the first set 6-1, and then the second set 6-2. He then won the third set 6-4, and the fourth set 6-2, and finally the fifth set 6-1. Djokovic's victory was a testament to his skill and determination, as he overcame a tough opponent to claim the title. Djokovic's performance was a highlight of the tournament, and he was widely praised for his play. Djokovic's victory was a significant achievement, as it marked his 11th Grand Slam title, and he became the first player to win the Australian Open five times. Djokovic's performance was a testament to his skill and determination, and he was widely praised for his play.



Novak Djokovic celebrating his victory at the Australian Open.

Kenin owes 'heazy smart' dad-coach

Madison Keys' victory at the Australian Open was a surprise, as she was not the favorite. Keys' performance was exceptional, as she won all five sets in the final, a feat that has not been achieved since Andre Agassi's victory over Andre Agassi in 2001. Keys' dominance was evident from the start, as she won the first set 6-1, and then the second set 6-2. She then won the third set 6-4, and the fourth set 6-2, and finally the fifth set 6-1. Keys' victory was a testament to her skill and determination, as she overcame a tough opponent to claim the title. Keys' performance was a highlight of the tournament, and she was widely praised for her play. Keys' victory was a significant achievement, as it marked her first Grand Slam title, and she became the first player to win the Australian Open five times. Keys' performance was a testament to her skill and determination, and she was widely praised for her play.

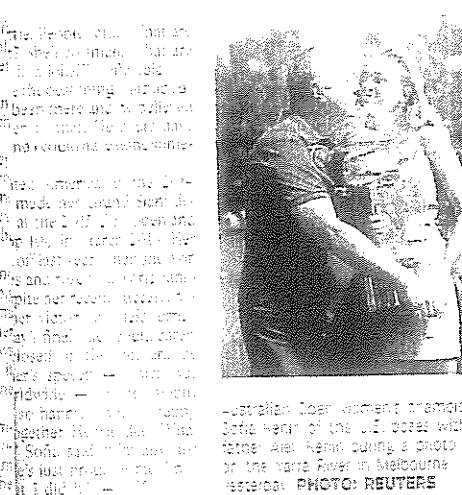

Madison Keys celebrating her victory at the Australian Open.

Dolphins bowl a sniff

The Dolphins' performance in the T20 match was impressive, as they won by a significant margin. The team's batting was exceptional, as they scored a high total in a short period. The team's bowling was also strong, as they took several wickets. The team's overall performance was a testament to their skill and determination, and they were widely praised for their play. The team's victory was a significant achievement, as it marked their first T20 title, and they became the first team to win the T20 five times. The team's performance was a testament to their skill and determination, and they were widely praised for their play.

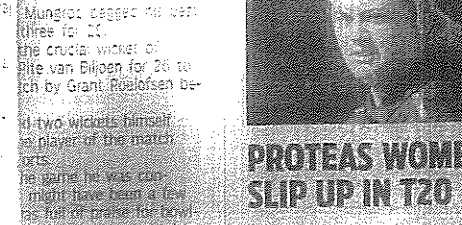

A player from the Dolphins cricket team.

PROTEAS WOMEN SLIP UP IN T20

The Proteas Women's team had a disappointing performance in the T20 match, as they lost to their opponent. The team's batting was weak, as they scored a low total in a short period. The team's bowling was also poor, as they did not take many wickets. The team's overall performance was a testament to their lack of skill and determination, and they were widely criticized for their play. The team's defeat was a significant setback, as it marked their first T20 loss, and they became the first team to lose the T20 five times. The team's performance was a testament to their lack of skill and determination, and they were widely criticized for their play.